

X-LIMITED

Personal Mobility

PRODUCT MANUAL





Scan the QR code to download the latest user materials
and obtain the latest updates and safety instructions.

DUALTRON

The dream of electric technology.

The pictures shown are for illustration purposes only. Actual product may vary.

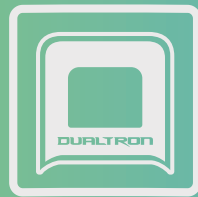

MINIMOTORS





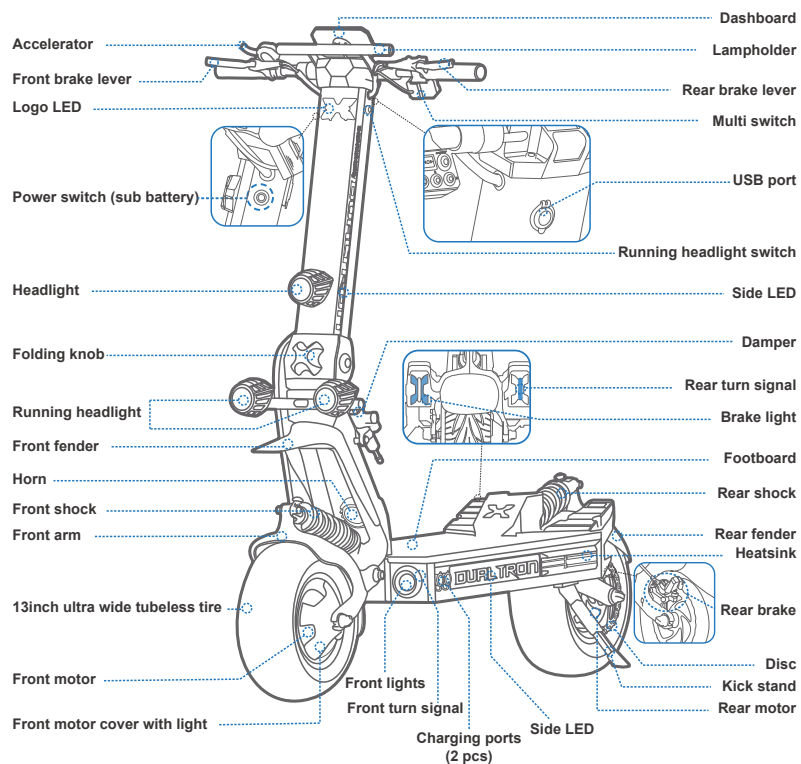

Diagram And Functions

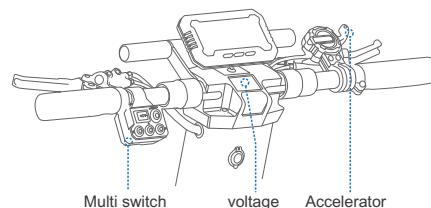

Handlebar Functions



Name	Function	Operation method
 Turn Signal Button	Turn on/off the left/right signal	Press the left/right side of the Turn Signal Button, the left/right turn signal will keep blinking.
 Headlight Button	Turn on/off the headlight	Press the Headlight Button, the headlight is on; Press it again, the headlight is off.
 Horn Button	Turn on the horn	Press the Horn Button, the scooter will beep once.
 Ambient Light Button	Turn on/off ambient light	Press the Ambient Light Button, turn on/off both sides of ambient light.
 Warning Light Button	Turn on the warning light	Press the Warning Light Button, the left&right signals will keep blinking until press the Warning Light Button again.
Voltage	Check sub battery voltage	Theoretical operating voltage for sub battery is from 8.25v to 12.6v.
Accelerator	Speed up	Pull the throttle to accelerate.



Specifications

	Item	Parameter
Product	Model	DUALTRON X LIMITED
	Length × Width × Height	1450x648x1400mm
	Folded: Length × Width × Height	1450x358x775mm
	Net Weight	82.9kg
Rider	Max. load	150kg
	Recommended Age	14–60 years old
Machine	Wheelbase	Approx.1100mm
	Ground Clearance	Approx.190mm
	Drive System	Two-wheel drive
	Max. Speed	Around 110km/h
	Theoretical Range	Around 170km
	Typical Range	Around 140km
	Max. Slope	Around 70% (35°)
	Traversable Terrain	Asphalt/flat pavement; obstacles < 5 cm; gaps < 5 cm
	Operating Temperature	-5 to 45°C
Storage Temperature	-20 to 50°C	
Display	Type	EY4 LCD Bluetooth Display(Ability to connect to DUALTRON APP)
	Size Of LCD	95*36mm, about 4.2 inches
Brake	Type	Hydraulic brake
	Quantity Of Pistons	4-pistons
	Electric Brake	ABS&EBS △ (Indicating the battery temperature exceeds 55°C,BMS start protection program, ABS/EBS fails.)



Specifications

Battery	Duration of Charging	Approx. 15 h(main battery)	Approx. 4 h(sub battery)
	Battery Capacity	84V60Ah	11V20Ah
	Charging Ambient Temperature	0 to 40°C (Battery temperature exceeds 55°C,BMS start protection program..)	
	Battery Management System	Over-heating, short circuit, over-current, over-discharge and over-charge protection	
Motor	Motor Type	BLDC Hub Motor	
	Nominal Power	2000W*2	
	Max. Power	6000W*2	
Charger	Input Voltage	100-120V/200-240V~	100~240V~
	Max. Output Voltage	95.45V 4A(main battery charger)	12.6V 5A(sub battery charger)
Tire	Type	13 inch wide tubeless tire	
	Tire Pressure	32 psi	
	Material	Rubber	
Suspension	Type	Hydraulic spring shock	
	Spring Rate	950 lbs/in.	

*Disclaimer: this is not a legal opinion or legal advice. The information provided herein (including in the App) is for your convenience and information purpose only. It is not intended to cover every piece of law and/or regulation that may be applicable to this product. DUALTRON explicitly hereby disclaims any and all warranty and/or representation, express or implied, related to completeness, accuracy, up-to-date of such information. DUALTRON reserves the right but not obligation to correct, implement and/or update the information. You shall use the information at your own risk. It is your sole responsibility to learn and understand any and all the law and/or regulation, requirements, prohibition, restriction and/or limitation imposed by either law, government authority, court, private party or the others that may apply to your use of this product.

*Theoretical Range: tested while riding with a full battery, 75 kg load, 25°C, at the speed of 25 km/h on average on pavement.

*Typical Range: tested while riding with a full battery, 75 kg load, 25°C, at the speed of 50 km/h on average on pavement. (Some of the factors that affect range include speed, number of starts and stops, ambient temperature, etc.)

*Max.Speed: tested while riding with a full battery,75kg load,25°C,straight road on flat road with no wind. (Some environmental factors can affect max speed,uneven roads, crooked roads, temperature, wind, etc.)



Packing List

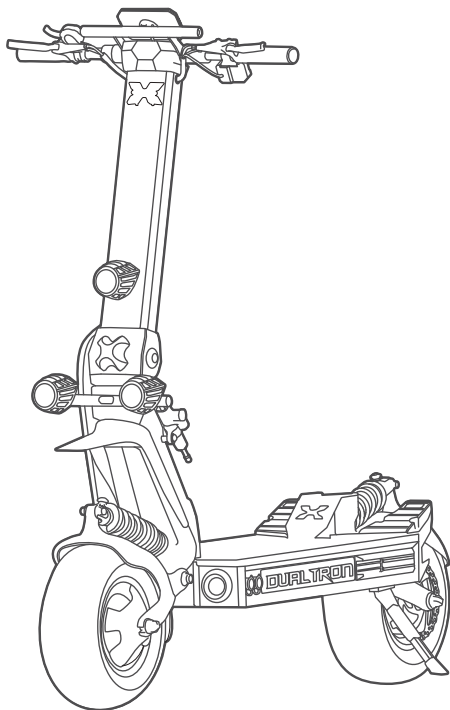

Accessories



- M6 Screw x 4
- M8 Screw x 2
- M6 Elastic Gasket x 4
- M8 Elastic Gasket x 2
- M6 Flat Gasket x 4



- Main battery charger x1
- sub battery charger x1

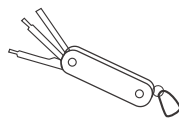

- Multitool x 1

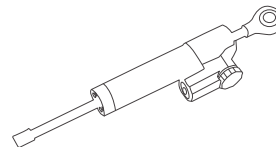

- Directional Damper x 1



- Screw Cap x 4



- Manual



Assembly

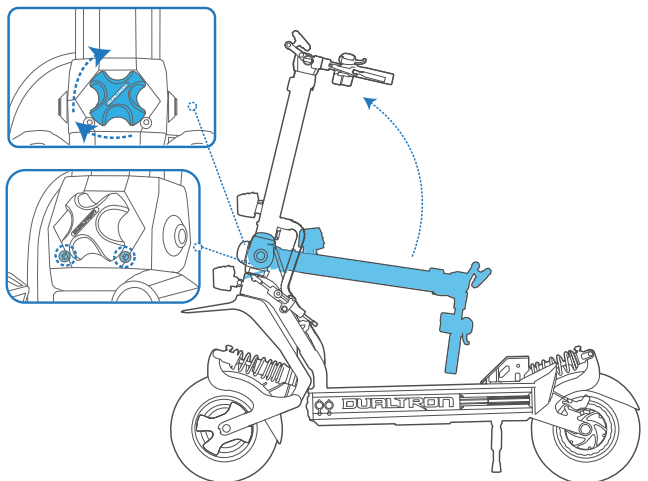

- ① Unfold the steering tube and lock the folding knob firmly.
- ② Install the two M8 screws with the multitool. ⚠️ (Folding knob may break and then fall down. The screws are very necessary.)

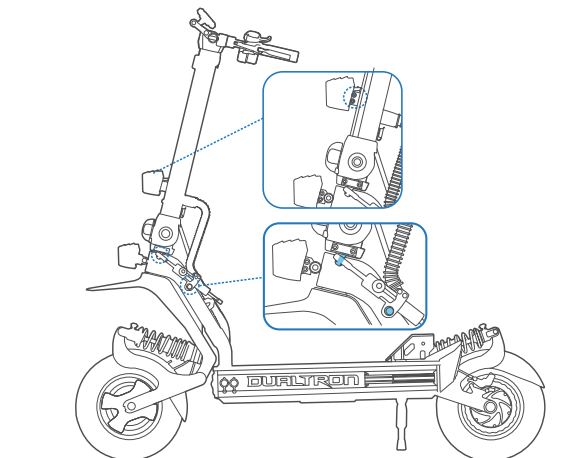

- ③ Install the screws for headlight/damper with the included multitool or An M6 Allen key.
⚠️ DO NOT use an electric screwdriver!

Assembly

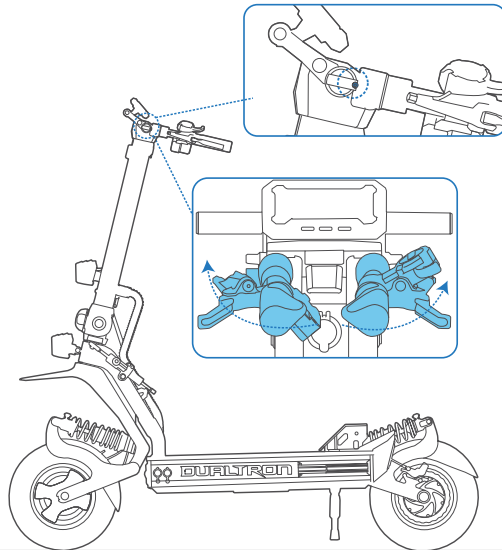

Unfold the handlebars, slide the folding handle lock into position to fix the handle firmly. **⚠️ During use, if the handle is slightly shaken, please unscrew the adjustment screw a little.**



Damper Adjustment

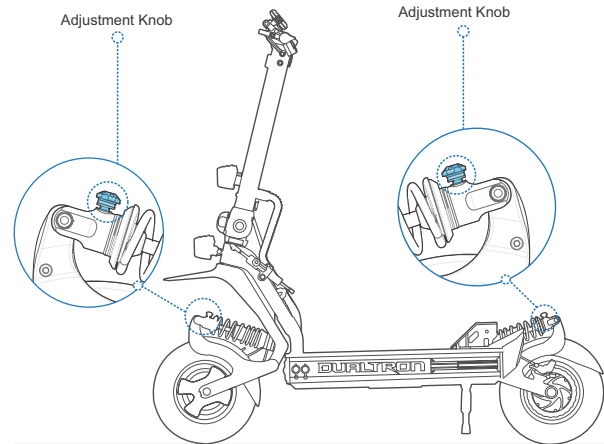

Turn the adjustment knob to the right to increase the shock rebound resistance.
Turn the adjustment knob to the left to decrease the shock rebound resistance. **Note:**
The shock is set to the default position before leaving the factory. Please follow the steps above to adjust it according to your riding habits.



Bluetooth Connection

APP Download Guide

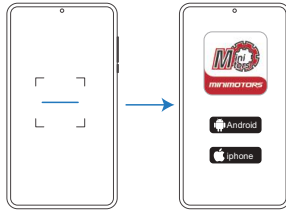

1. Scan the QR code to download the APP.
2. Choose the mobile phone system that suits you to install, and register / log in.



1. Search "DUALTRON" in the application and download it, and register / log in.

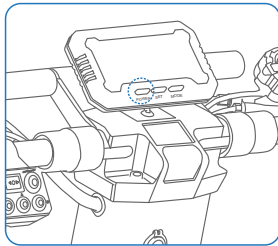

Power on the scooter.

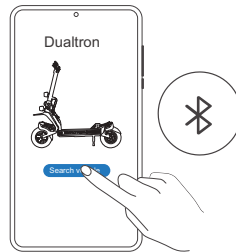

Click "Search vehicle" and pair with your scooter. * The scooter is connected to the Dualtron app when the Bluetooth symbol lights up.

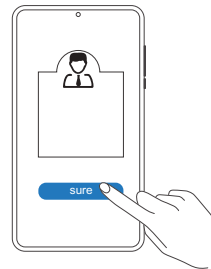

Select bind as owner



How to Ride

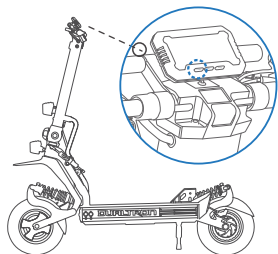

1. Power on the scooter and choose the speed mode. * Please choose the speed mode before riding! Note: Speed mode can be choose via the Dualtron app.

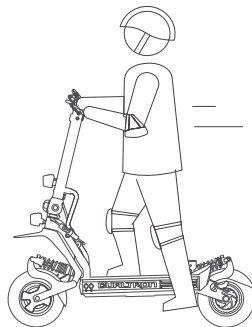

2. Stand on the footboard with one foot and push off with the other foot to start gliding. *Make sure you have disabled SAFE mode. (SAFE mode setting via Dualtron app. Deactivate safe mode by squeezing brake lever.)

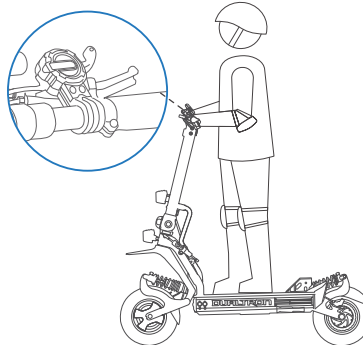

3. Put both feet on the footboard and stand stably. Pull the throttle to speed up.

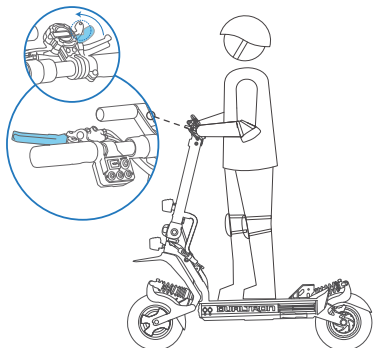

4. Slow down by releasing the throttle and squeezing brake levers.

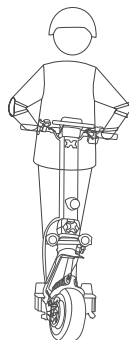

5. To turn, shift your body and turn the handlebar slightly. * Please watch out for road conditions, sufficient turning space is required.

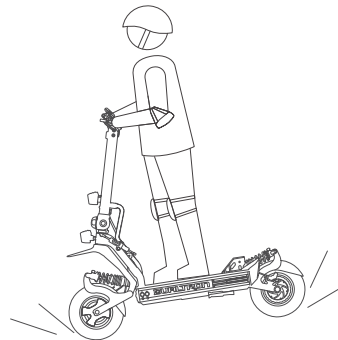

When hard braking, serious danger or injury may occur. Maintain a moderate speed and look out for potential hazards.



Folding

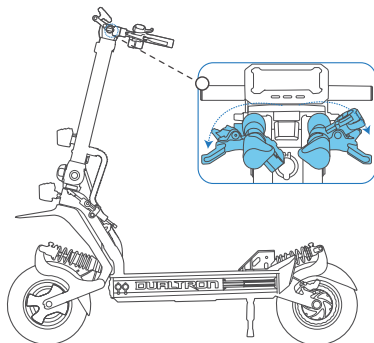

Fold the handlebars, slide the folding handle lock out of position to release handles.

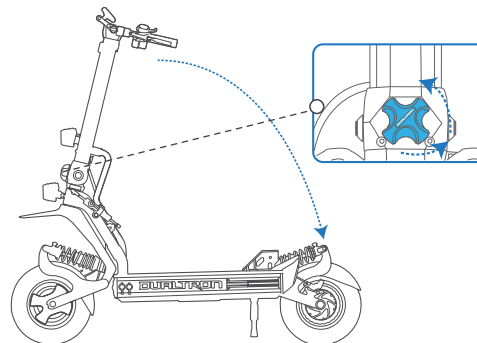

Unscrew the folding knob and M8 screws, then fold the steering tube. **⚠ Risk of pinching!**

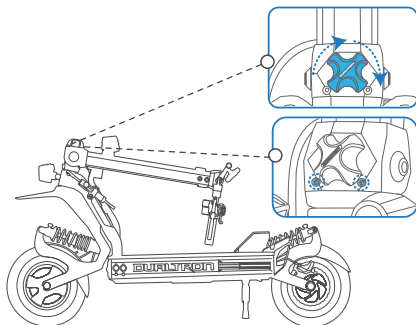

Install back the folding knob prevent loss.

Note: Please keep these two M8 screws, they must be installed when unfolding

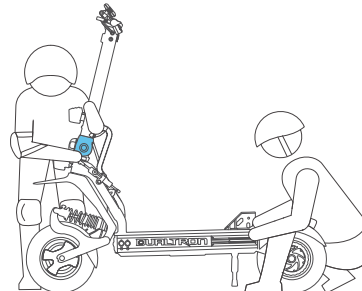

Lift up the bottom of the front fork and rear foot pedestal to carry if necessary. Make sure the scooter is carried by two or more people. **⚠ Risk of pinching!**







